

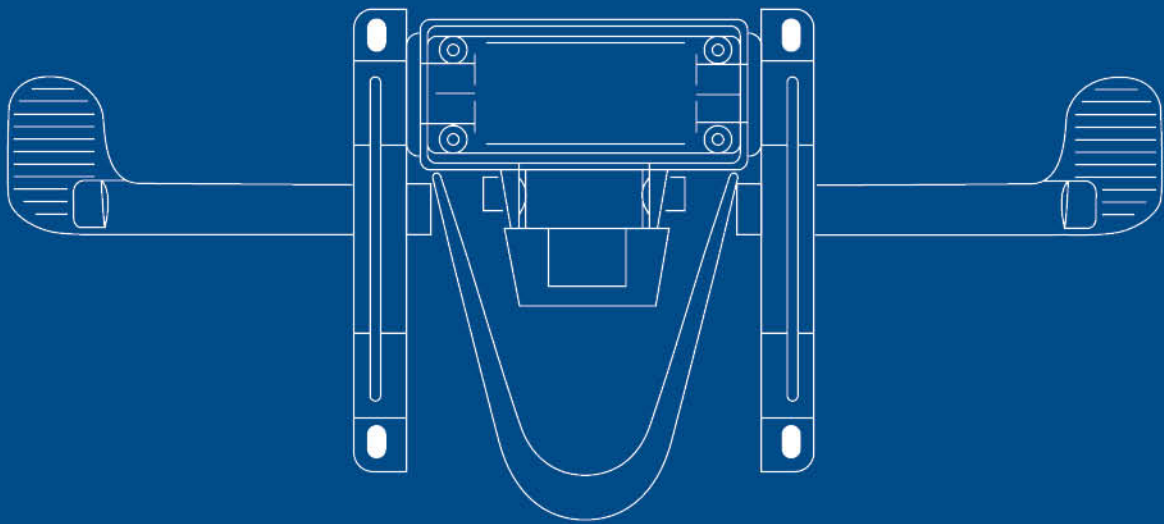

WORLD WIDE PRODUCTS

True Bond of Precision and Excellence



Product Catalogue

Office Furniture - Parts & Components

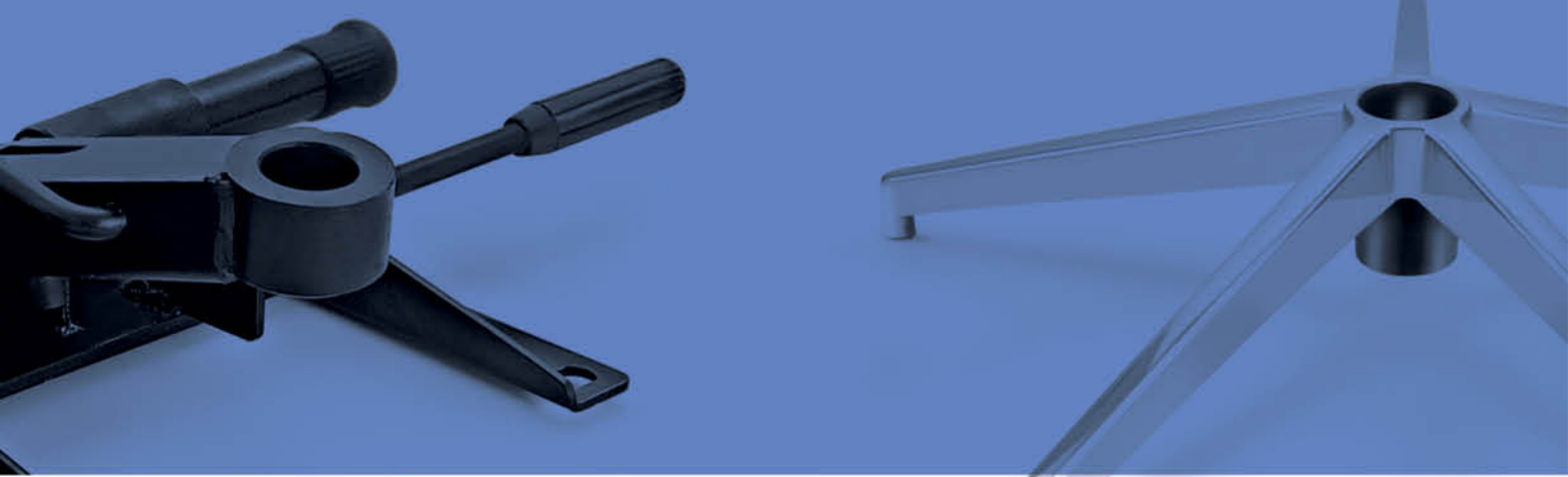

Vision

We pledge to:

- Ensure excellence by incorporating world class technologies in our products.
- Provide a working environment that is conducive to the professional growth
- Care for all our employees in sickness and in health.
- Maintain hygienic working conditions in our factory.
- Preserve and protect our environment.

Company Profile

World Wide Products is a reputed company with more than three decades of experience to its credit in the manufacture, supply and export of office furniture parts and components.

The production, treatment and processing of every component incorporates most modern technology using state-of-the art machinery, sourced from the very best in the world. The manufacturing facility is located in a sprawling 1,25,000 sq. ft. complex at Mandi Gobindgarh, Punjab. There is a dedicated work force of more than 300 skilled and semi skilled workers to handle the operations of this magnitude.

Being pioneers in office furniture component industry, World Wide is all about optimizing value out of each rupee spent by our esteemed clientele. Our products are developed on the concept of simplicity, smart design and precision workmanship. As a result each component remains functional and retain their inherent qualities even after prolonged and vigorous usage. Furthermore, each and every World Wide product / component combines traditional values with modern blueprint that ultimately translates into comfort in a well-designed chair.

Pan India Sales & Marketing Network

Our sales and marketing operations span across the length and breadth of India. We serve our customers through a well established dealer and distributor network which is active in 28 (twenty eight states)

Employee Skill Upgrade Program

At World Wide we recognize the importance of lifelong learning and the need for continual education and skill upgrade. We conduct regular training programs to help our employees to better appreciate their true value and reward their skills. This exercise boosts their moral, improves their efficiency and productivity.

In the world of fast evolving technologies, we remain dedicated to excellence in every facet of our products and offer nothing but the best.

New Horizons – New Hopes

Continuing with the tradition of excellence, World Wide Products introduces for the first time in India the globally famous, 'Tandem Sling Seating System', this new product initiative is in line with the 'Make In India' movement . This seating system is totally indigenous and is being manufactured at the modern plant at Mandi in Punjab. It is offered in Mild Steel and Aluminum Metal Alloy and is offered in units of 1, 2, 3, 4 and 5 seater options.



Business Enquiries & Catalogue on request

Certifications & Accreditations

BIFMA

UQSR



We proudly say that we manufacture everything in-house, We believe that Nation's growth is in our own manufacturing and we stay with that practically



*'Our roots are as deep as
our commitment to quality'*

Works at Mandi-Gobindgarh, Punjab



Design Development & Customization

We have in-house design, research and development facility which makes it effortlessly possible to produce full scale prototypes of various kind of furniture for Office, Restaurants and Cafes based on customers design and engineering requirement for a specific product line.

Material and component testing laboratory is also in place within the factory to carry out efficacy test of our prototypes.

Our Strengths

We have the necessary prerequisites, to optimize production values and maintain consistent quality at all times. Some of them are:

- Installed capacity of 18 Lakh units of mechanism per annum.
- Mechanised production line.
- A modern material testing Laboratory.
- All products conform to BIFMA Standards of the USA.



Managing Director - Mr. Jaspal Sachdeva

Managing Director's Message

Dear Friends

I am happy to present the new World Wide Products catalogue.

Let me take this opportunity to thank our valued customers whose continued patronage and confidence in our products has always inspired us to improve our quality and extend best of services. It has also encouraged us to provide best value for their money.

Let me assure, that in years to come World Wide Products will continue to serve the Office Furniture parts & components Market in India and will remain committed to high standards of the industry. We will always remain focused on the needs of our customers, and strive to earn their confidence by offering efficient and reliable products, at par with the best in world.

Over the years I have felt the need to explore new business avenues within the ambit of seating systems industry. After due deliberations with the core group and introspection, I have zeroed in on, 'Tandem Sling Seating System', which is the internationally preferred choice for large public waiting areas at the airports, railway stations and hospitals. It gives me great pleasure to inform that this seating system is already in production at our fully automated manufacturing facility - at Mandi, Gobindgarh in Punjab - with state-of-the-art machinery.

This effort is in line with 'Make in India' drive, which underlines the commercial objective of India.

I, humbly seek the support of our esteemed clientele, along with the co-operation of our employees, I also would like to thank our well-wishers and associates who have contributed to the growth of World Wide Products over the years. In the end let me reiterate that without your continuous support the journey so far would not have been possible.

Thank You

CONTENTS

KNEE TILT

8



SYNCHRO TILT

12



CENTRE TILT

15



BACK PUSH TILT

18



SEAT PLATE

22



CHAIR BASE

25



CAFE TABLE BASE

36



SALOON MECHANISM

44



BACK PATTI

47



ARM REST

49



STUDY CHAIR FITTING

53



HEIGHT ADJ & LEGS

54



FITTING & ACCESSORIES

55



SOFA BASE

58



BAR STOOL ACCESSORIES

59



PLASTIC BACK SHELL

60



CASTOR & ADJUSTOR

61



CHAIR KIT

62



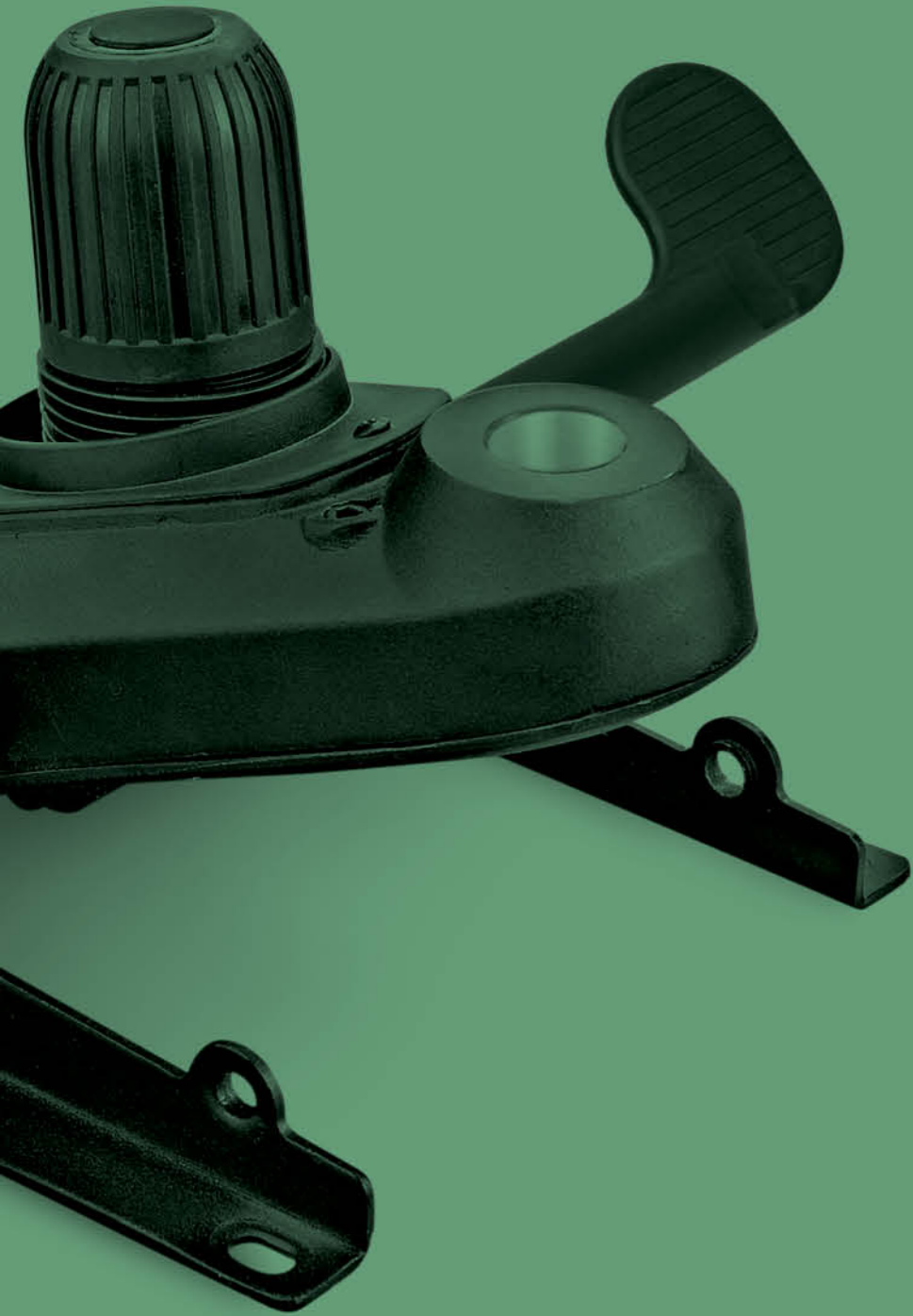

| Tilt & Fixed Mechanism |



WKT-001

Lever A for seat height adjustment
Lever B for Four lock position with a return-preventing system on the backrest

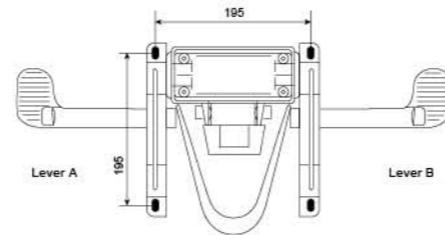

WKT-003

Lever A for seat height adjustment
Lever B for lock unlock system

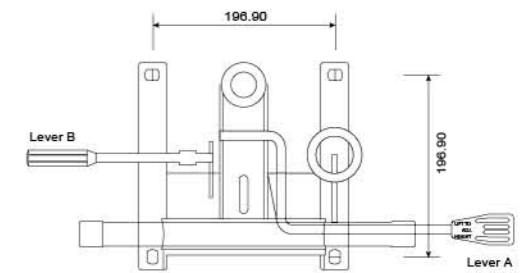

WKT-002

Lever A for seat height adjustment
Lever B for Four lock position with a return-preventing system on the backrest

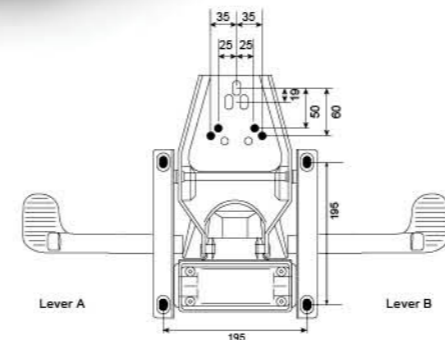

WKT-004

Lever A for seat height adjustment
Lever B for Four lock position with a return-preventing system on the backrest

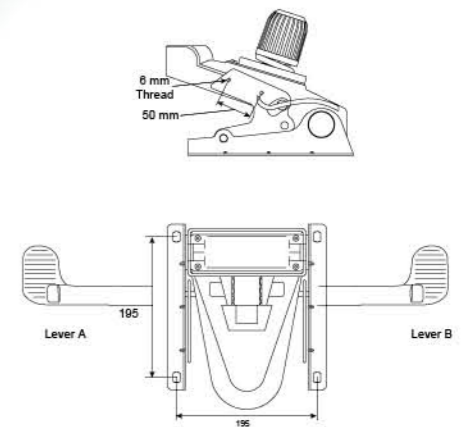

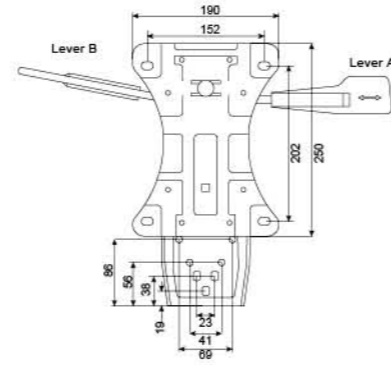

Lever A for seat height adjustment
Lever B for Four lock position with a return-preventing system on the backrest

WST-101

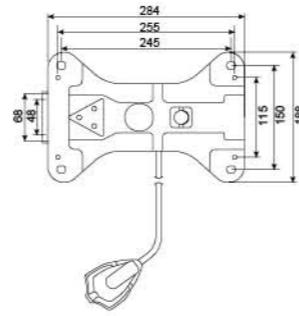

Lever for seat height adjustment and lock unlock system

WST-102

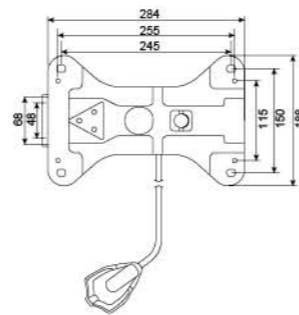

Lever for seat height adjustment and lock unlock system

WST-103

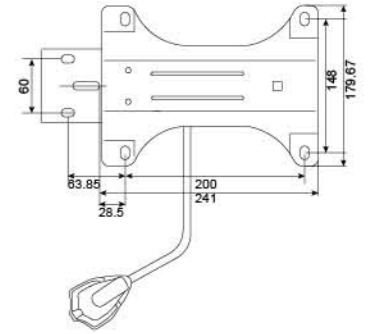

Lever for seat height adjustment and lock unlock system

WST-107

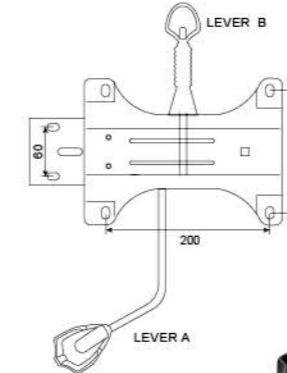
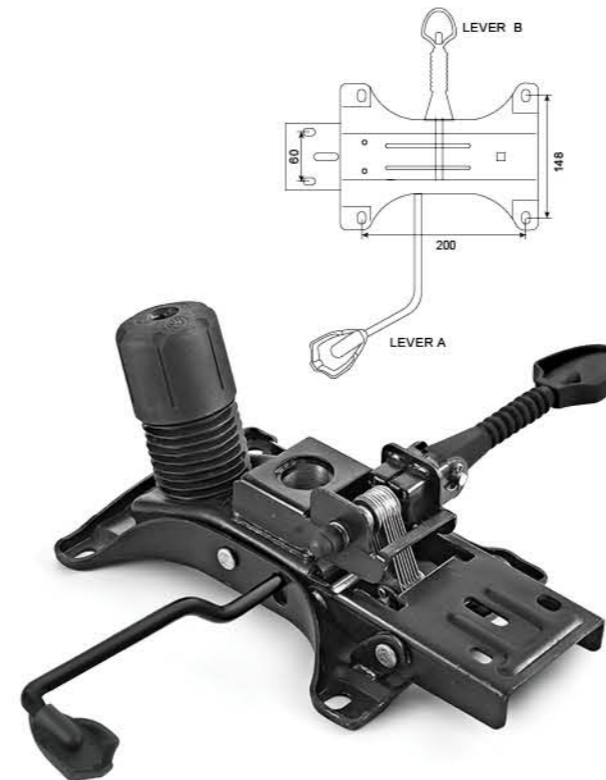

Lever A for seat height adjustment
Lever B for locking at any angle

WST-108

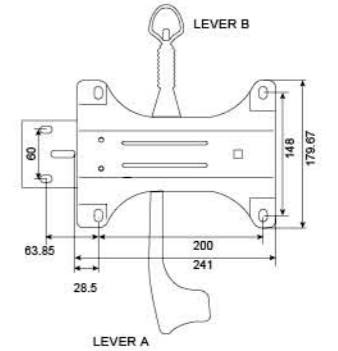

DESIGNER GRIPPER

Lever A for seat height adjustment
Lever B for locking at any angle

WST-109



WST-110

Lever for seat height adjustment and lock unlock system

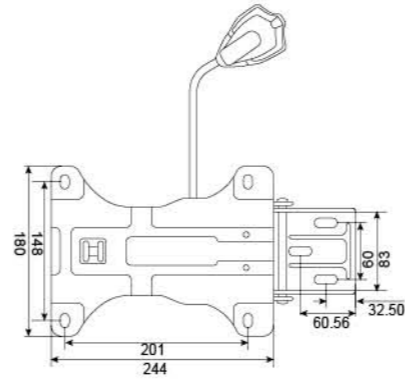

Sliding Synchro Tilt



WST-111

Lever A for seat height adjustment
Lever B for locking at any position

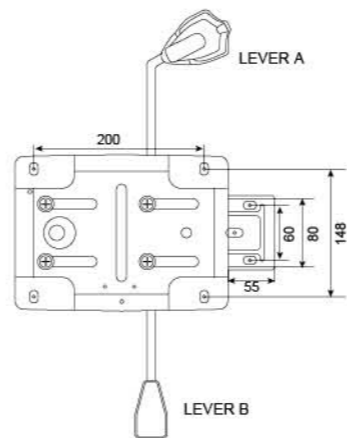

WCT-201

Lever for seat height adjustment and lock-unlock system

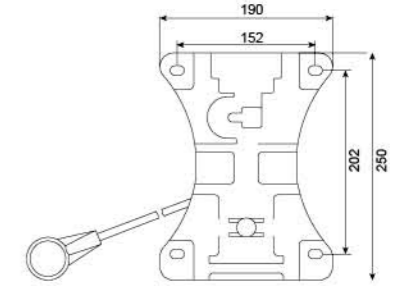

WCT-203

Lever A for seat height adjustment
Lever B for locking at any angle

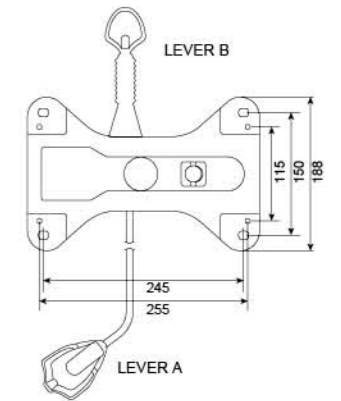

WCT-204

Lever for seat height adjustment and lock-unlock system

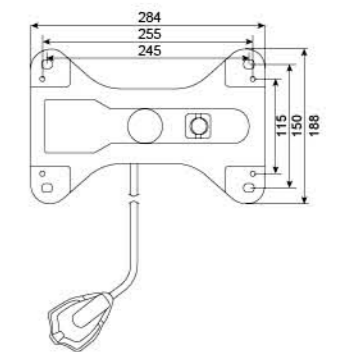



WCT-205

Lever for seat height adjustment and lock-unlock system

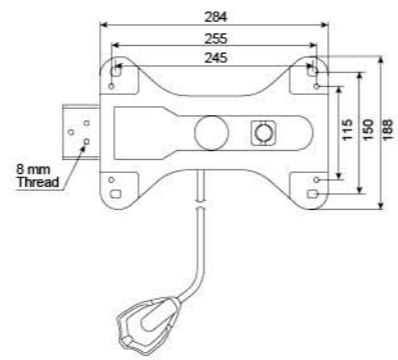

WCT-207

Lever for seat height adjustment and lock-unlock system

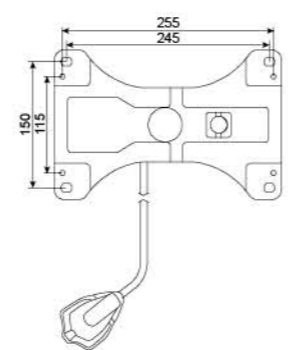

WCT-208

Lever for seat height adjustment and lock-unlock system

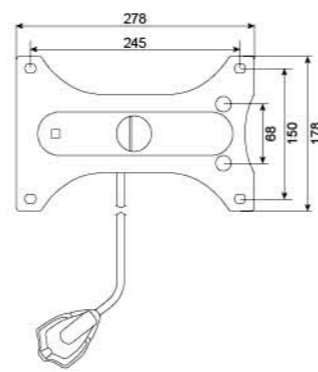

WCT-210

Lever for seat height adjustment and lock-unlock system

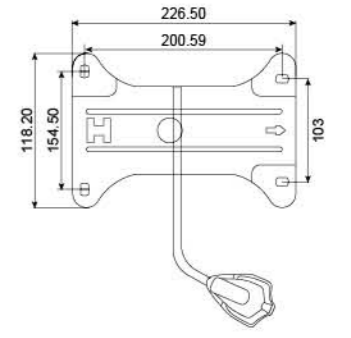

WCT-211

Lever A for seat height adjustment
Lever B for locking at any angle

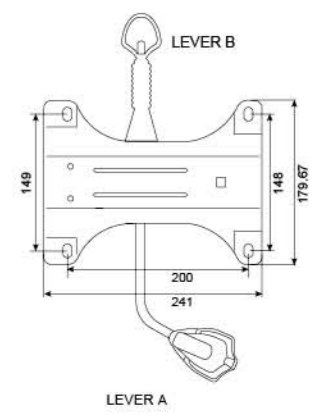

WCT-213

Lever A for seat height adjustment
Lever B for locking at any angle

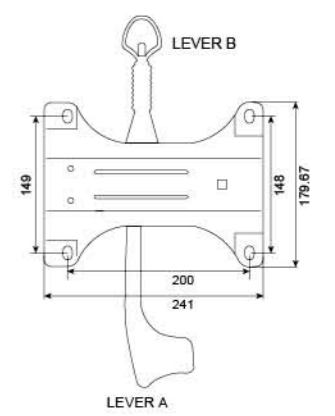



Product Code	Description
WPT-301	Back Push
WPT-302	Back Push with Dibbi
WPT-303	Back Push without Lock

Lever A for seat height adjustment
Lever B for lock unlock system

WPT-301



Product Code	Description
WPT-304	Back Push
WPT-305	Back Push with Dibbi
WPT-306	Back Push without Lock

Lever A for seat height adjustment
Lever B for lock unlock system

WPT-304

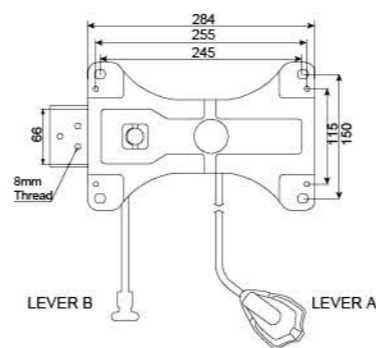
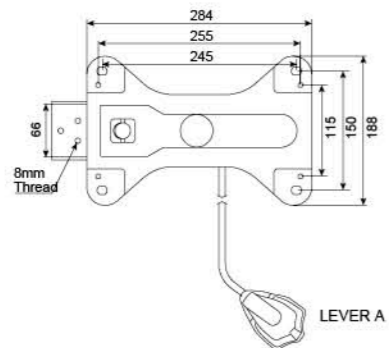

Product Code	Description
WPT-307	Back Push
WPT-308	Back Push with Dibbi
WPT-309	Back Push without Lock

Lever A for seat height adjustment
Lever B for lock unlock system

WPT-307



Product Code	Description
WPT-310	Back Push
WPT-311	Back Push with Dibbi
WPT-312	Back Push without Lock

Lever A for seat height adjustment
Lever B for lock unlock system

WPT-310

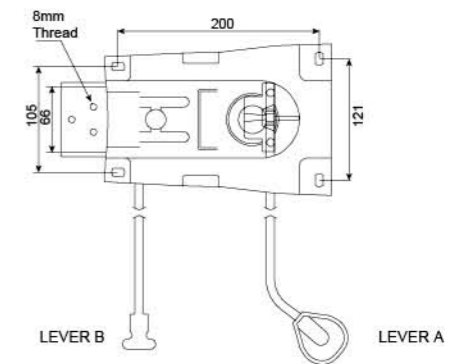
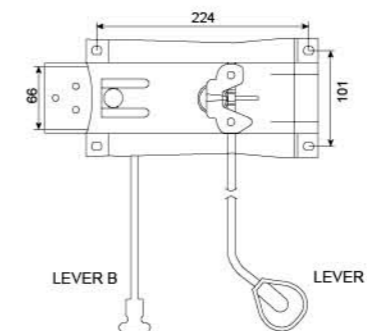



WPT-313

Lever A for seat height adjustment
Lever B for lock unlock system

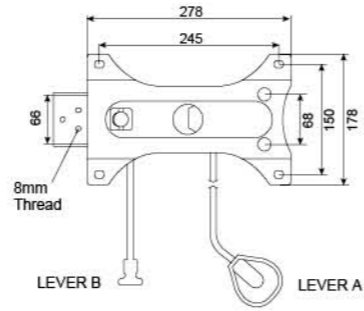

WPT-322

Lever A for seat height adjustment
Lever B for lock unlock system

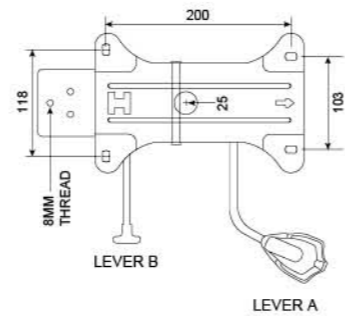

WPT-326

Lever A for seat height adjustment
Lever B for lock unlock system

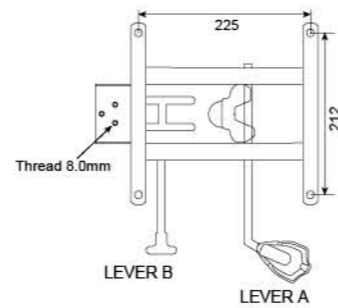

Product Code	Description
WPT-322	Back Push
WPT-323	Back Push without lock



WPT-317

Lever A for seat height adjustment

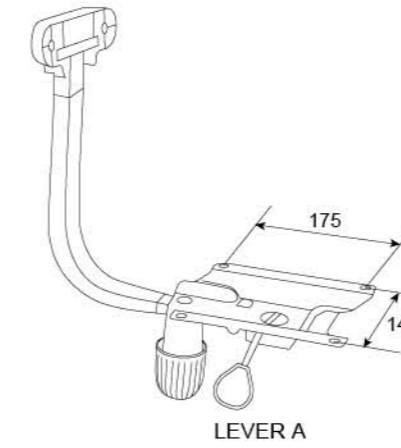

WPT-318

Lever A for seat height adjustment

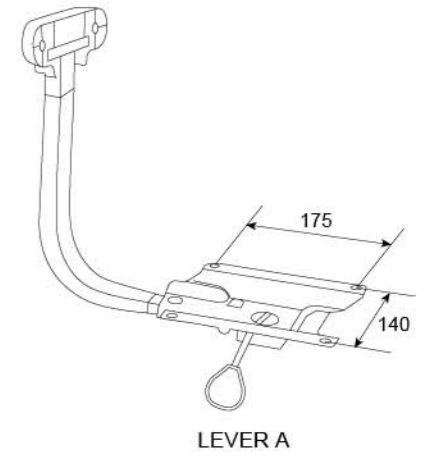

WPT-320



WPT-321



WSP-401
Lever for seat height adjustment

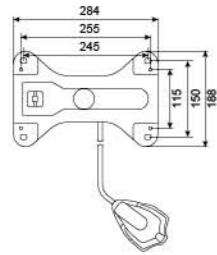

WSP-402
Lever for seat height adjustment

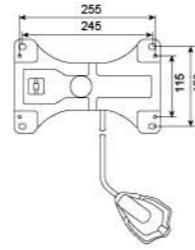

WSP-403
Lever for seat height adjustment

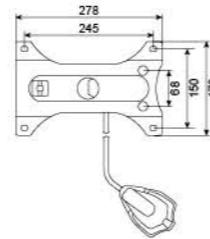

WSP-404
Lever for seat height adjustment

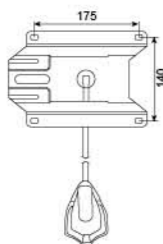

WSP-406
Lever for seat height adjustment

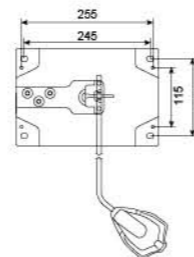

WSP-408
Lever for seat height adjustment

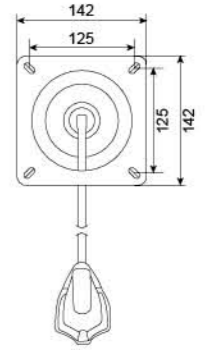

WSP-409
Lever for seat height adjustment

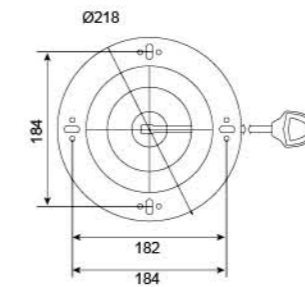

WSP-410
Lever for seat height adjustment

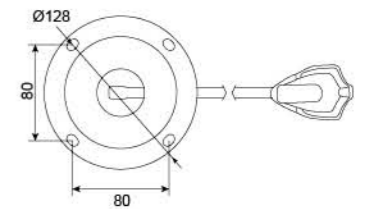

WSP-419

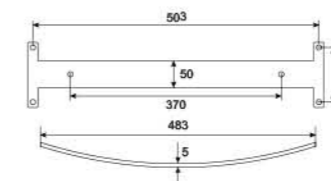

WSP-421

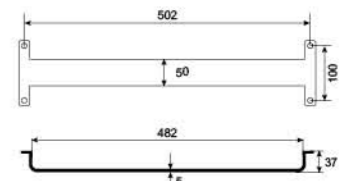



WSP-413
Lever for seat height adjustment

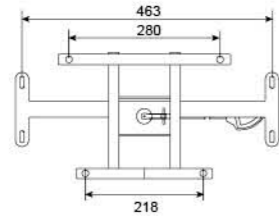

WSP-414
Lever for seat height adjustment

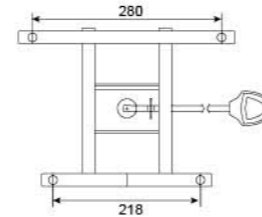

WSP-415
Lever for seat height adjustment

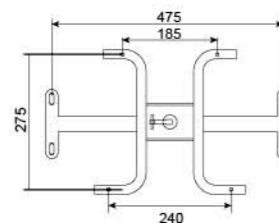

WSP-416
Lever for seat height adjustment

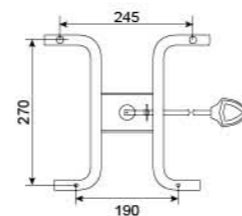

Chair Base

Application :

Office chairs, Airport managing staff chairs, Sofa base, Restaurant & Cafeteria seating.

Material Specification :

Aluminium : Aluminium alloy is pressure die-cast to form the shape and the surface is then polished to perfection.

Metal : High quality cold rolled sheet is pressed and welded to form the shape.

Chrome Plating : The surface is then polished and chrome plated.

Powder Coating : The surface is then cleaned with acid to remove rust and powder coated.

Plastic : Injection Moulding process is deployed to form the shape using high quality material.

Customization :

Legs : Choice of four and five legs base

Colors : Choice of colors; Chrome, Silver Grey, Blue, Cherry and Black.

Dimensions :

Cylinder Diameter : 50 mm

Diameter of base : Ranging from 500 mm to 710 mm

Height : Ranging from 35 mm to 135 mm

Colors Available :



[We undertake special projects and develop products as per customers' specifications and designs]

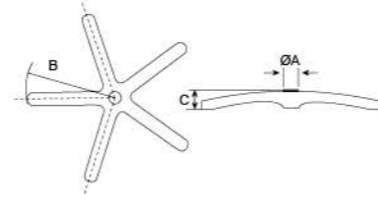

Product Code	A(mm)	B(mm)	C(mm)
WCB-501	50	325	83

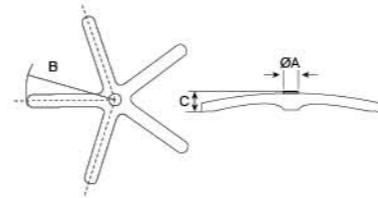

Product Code	A(mm)	B(mm)	C(mm)
WCB-502	50	325	85

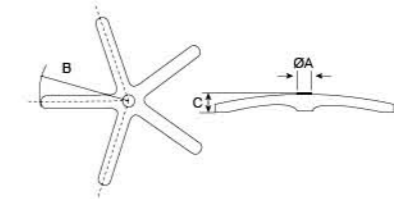

Product Code	A(mm)	B(mm)	C(mm)
WCB-505	50	345	93
WCB-506	50	300	93



Product Code	A(mm)	B(mm)	C(mm)
WCB-507	50	315	84

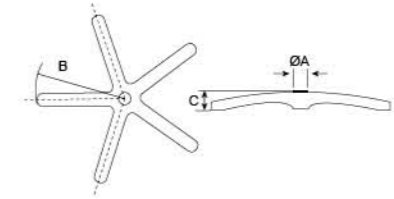

Product Code	A(mm)	B(mm)	C(mm)
WCB-509	50	350	60
WCB-510	50	300	60



Product Code	A(mm)	B(mm)	C(mm)
WCB-513	50	345	35
WCB-513 A	50	320	35
WCB-514	50	295	35

Thickness - 1.5mm

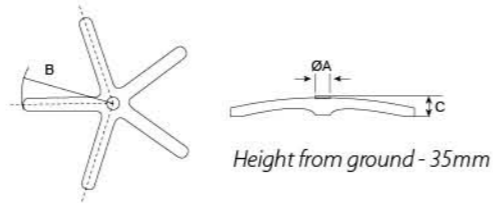

Product Code	A(mm)	B(mm)	C(mm)
WCB-515	50	350	80
WCB-515 A	50	320	80
WCB-516	50	290	80

Thickness - 1.2mm

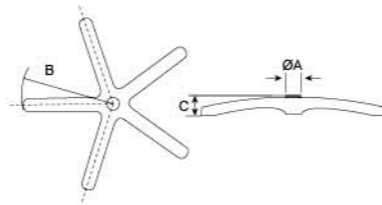

Product Code	A(mm)	B(mm)	C(mm)
WCB-544	50	350	80
WCB-544 A	50	320	80
WCB-545	50	290	80

Thickness - 1.0mm



Product Code	A(mm)	B(mm)	C(mm)
WCB-517	50	350	105
WCB-518	50	320	105
WCB-534	50	275	105
WCB-534 A	50	250	90

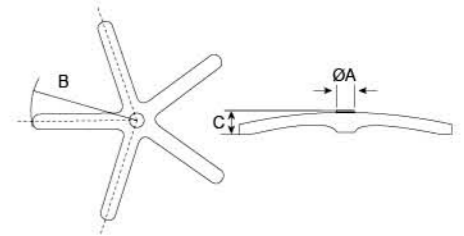

Product Code	A(mm)	B(mm)	C(mm)
WCB-519	50	325	85
WCB-520	50	300	78

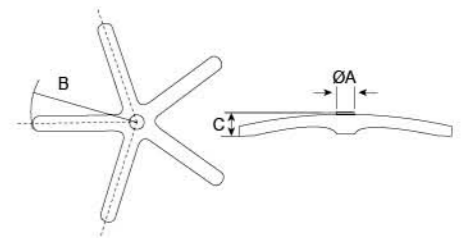



Product Code	A(mm)	B(mm)	C(mm)
WCB-523	50	330	73
WCB-524	50	300	73

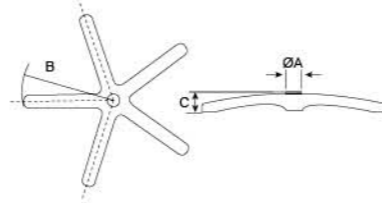

Product Code	A(mm)	B(mm)	C(mm)
WCB-527	50	320	95

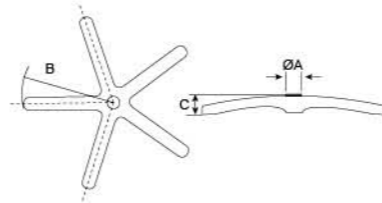

Product Code	A(mm)	B(mm)	C(mm)
WCB-530	50	320	95
WCB-531	50	300	85



Product Code	A(mm)	B(mm)	C(mm)
WCB-536	50	350	90



Product Code	A(mm)	B(mm)	C(mm)
WCB-535	50	322	50

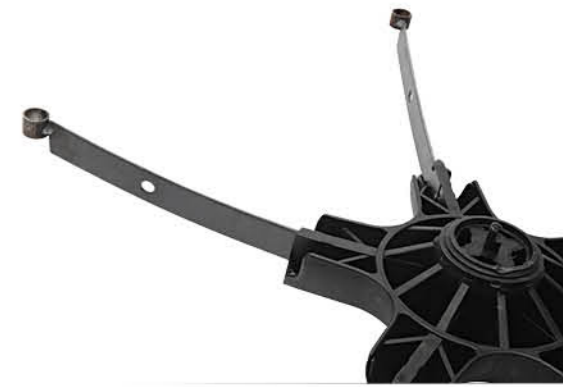

Plastic Base With Metal Insert



Metal Insert

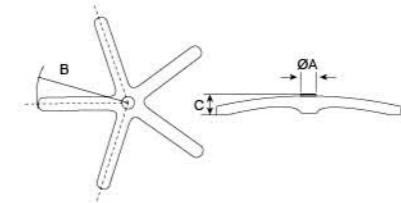

Product Code	A(mm)	B(mm)	C(mm)
WCB-539	50	320	75
WCB-540	50	300	80



Product Code	A(mm)	B(mm)	C(mm)
WCB-541	50	350	75

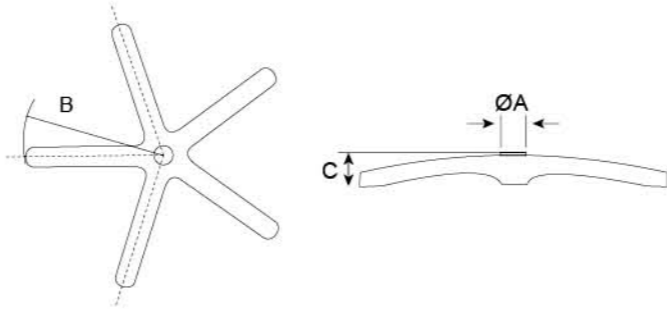

Product Code	A(mm)	B(mm)	C(mm)
WCB-542	50	350	135

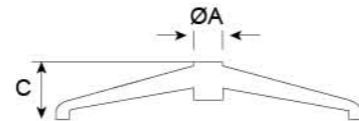

Product Code	A(mm)	B(mm)	C(mm)
WCB-546	50	350	85
WCB-547	50	320	85

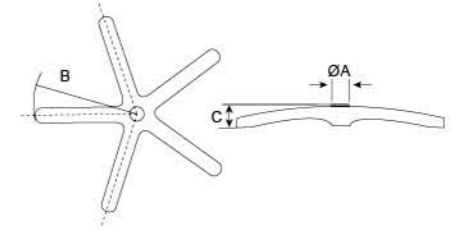

Product Code	A(mm)	B(mm)	C(mm)
WCB-548	50	350	70
WCB-549	50	320	70

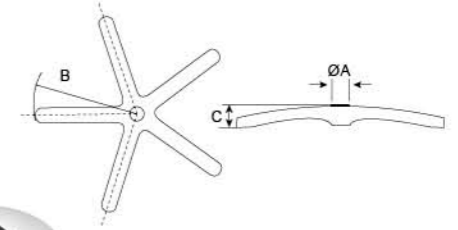

Product Code	A(mm)	B(mm)	C(mm)
WCB-553	50	355	60



Product Code	A(mm)	B(mm)	C(mm)
WCB-554	50	330	85



Product Code	A(mm)	B(mm)	C(mm)
WCB-556	50	345	138
WCB-556 A	50	320	138

Chair Base in Gray Color



Product Code	A(mm)	B(mm)	C(mm)
WCB-555	50	345	85
WCB-555 A	50	320	85



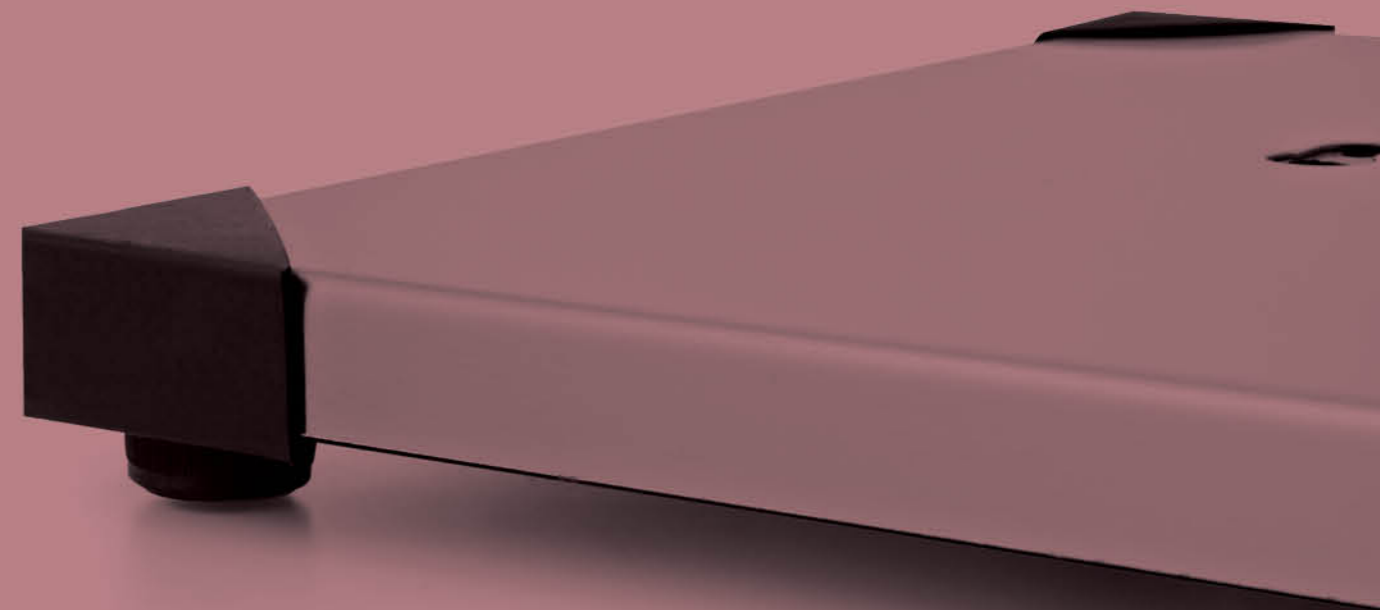

| Cafe Table Base |

Cafe Table Base

Application :

Office, Restaurants, Cafeterias and MC-Donalds type floor areas.

Material Specification :

Metal : High quality cold rolled sheet is pressed and welded to form the shape.

Chrome : The surface is polished and then chrome plated to perfection.

Powder Coating : The surface is then cleaned with acid to remove rust and powder coated.

Stainless Steel : High grade stainless steel is pressed over the metal surface to form the shape over the process.

Product Code : Cafe table base in Metal: WCA-601 to WCA-624

Cafe table base in Stainless steel : WCA-651 to WCA-668

Customization :

Base : Choice of different shapes like round, square and oval

Colors : Choice of colors; Chrome, Silver Grey, Blue, Cherry and Black.

Thickness : Choice of thickness; 6mm to 8mm

Stainless Steel : Choice of grades 304 and 202

Colors Available :



[We undertake special projects and develop products as per customers' specifications and designs]

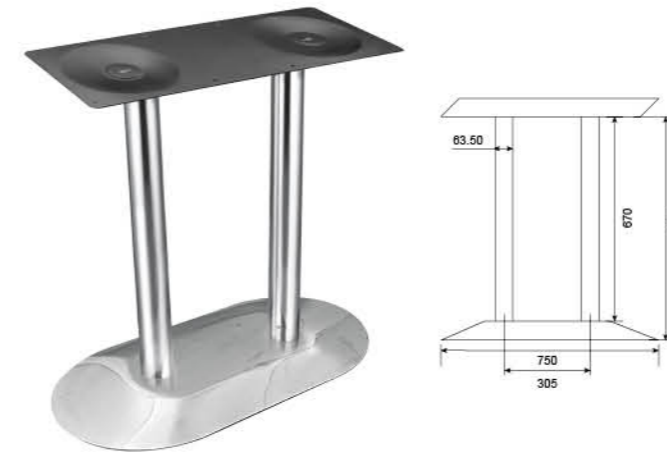

WCA-601



WCA-602



Product Code	Round Base Set	Finish
WCA-607	Ø 470 mm	Chrome
WCA-607A	Ø 470 mm	Powder Coated
WCA-609	Ø 400 mm	Chrome
WCA-609 A	Ø 400 mm	Powder Coated



Product Code	Square Base Set
WCA-603	380 mm
WCA-616	450 mm

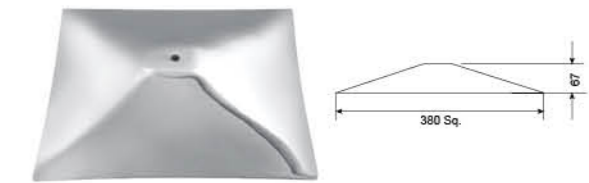

Product Code	Square Base
WCA-604	380 mm
WCA-617	450 mm

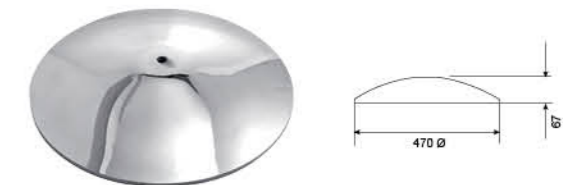

Product Code	Round Base	Finish
WCA-608	Ø 470 mm	Chrome
WCA-608A	Ø 470 mm	Powder Coated
WCA-610	Ø 400 mm	Chrome
WCA-610 A	Ø 400 mm	Powder Coated
WCA-612	Ø 300 mm	Chrome
WCA-612 A	Ø 300 mm	Powder Coated

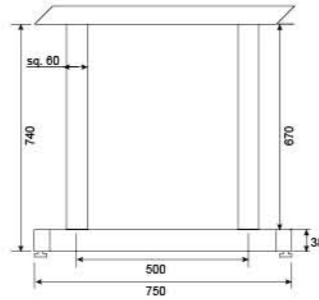

Product Code	Length	Width	Plate / Frame
WCA-618	750mm	380 mm	Plate
WCA-618 A	750mm	380 mm	Frame

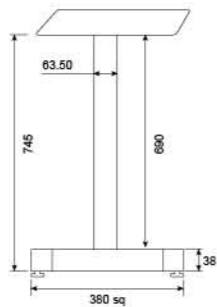

Product Code	Square Base Set	Plate / Frame
WCA-619	380mm	Plate
WCA-619 A	380mm	Frame
WCA-620	450mm	Plate
WCA-620 A	450mm	Frame



Product Code	Square Base
WCA-622	380mm
WCA-623	450 mm

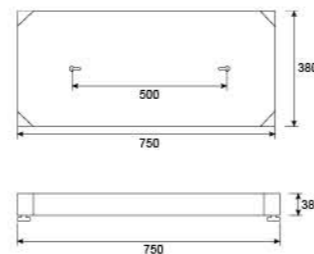

WCA- 621

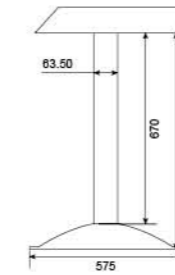

Product Code	Round Base Set	Finish
WCA-605	Ø 575 mm	Chrome
WCA-605 A	Ø 575 mm	Powder Coated

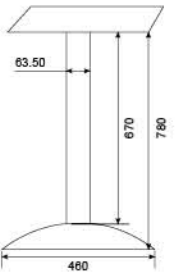

Product Code	Round Base Set	Finish
WCA-613	Ø 380 mm	Chrome
WCA-614	Ø 450 mm	Chrome

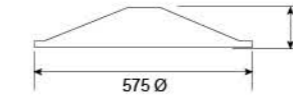

Product Code	Round Base Set	Finish
WCA-606	Ø 575 mm	Chrome
WCA-606 A	Ø 575 mm	Powder Coated



Floor Mounted Base

WCA-624

All bases are available with PVC shoes (optional)

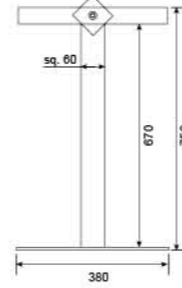
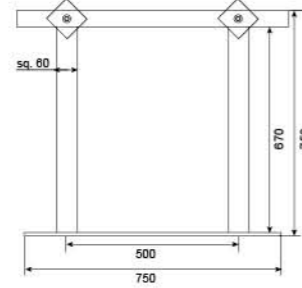

Product Code	Length	Width	Plate / Frame
WCA-651	750mm	380 mm	Frame
WCA-651 A	750mm	380 mm	Plate

Product Code	Square Base	Plate / Frame
WCA-653	380mm	Frame
WCA-653 A	380mm	Plate
WCA-661	450mm	Frame
WCA-661 A	450mm	Plate

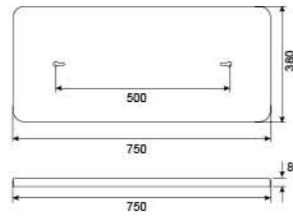

WCA-652

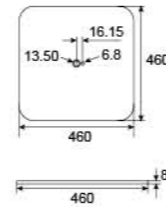

Product Code	Square Base
WCA-654	380 mm
WCA-662	450 mm

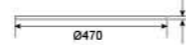
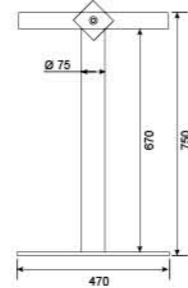

Product Code	Round Base	Plate / Frame
WCA-655	Ø 575mm	Frame
WCA-655 A	Ø 575mm	Plate
WCA-657	Ø 470mm	Frame
WCA-657 A	Ø 470mm	Plate
WCA-659	Ø 380mm	Frame
WCA-659 A	Ø 380mm	Plate

Product Code	Round Base
WCA-656	Ø 575mm
WCA-658	Ø 470mm
WCA-660	Ø 380mm

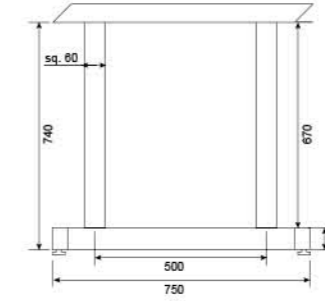

Product Code	Length	Width	Plate / Frame
WCA-663	750mm	380 mm	Frame
WCA-663 A	750mm	380 mm	Plate

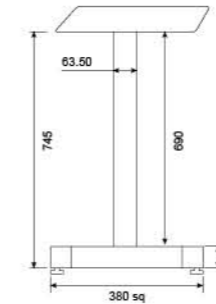

Product Code	Squre Base	Plate / Frame
WCA-664	380mm	Frame
WCA-664 A	380mm	Plate
WCA-665	450mm	Frame
WCA-665 A	450mm	Plate

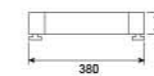

Product Code	Square Base
WCA-667	380 mm
WCA-668	450 mm

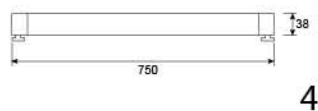
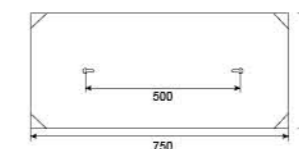

WCA-666



WSM-701



WSM-702



WSM-703



WSM-704

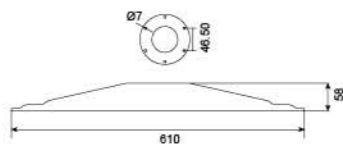
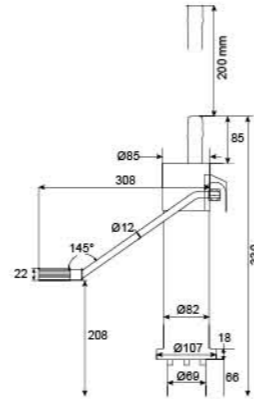

WSM-705



WSM-705-A

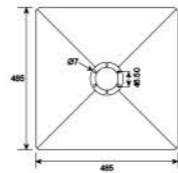

WSM-716

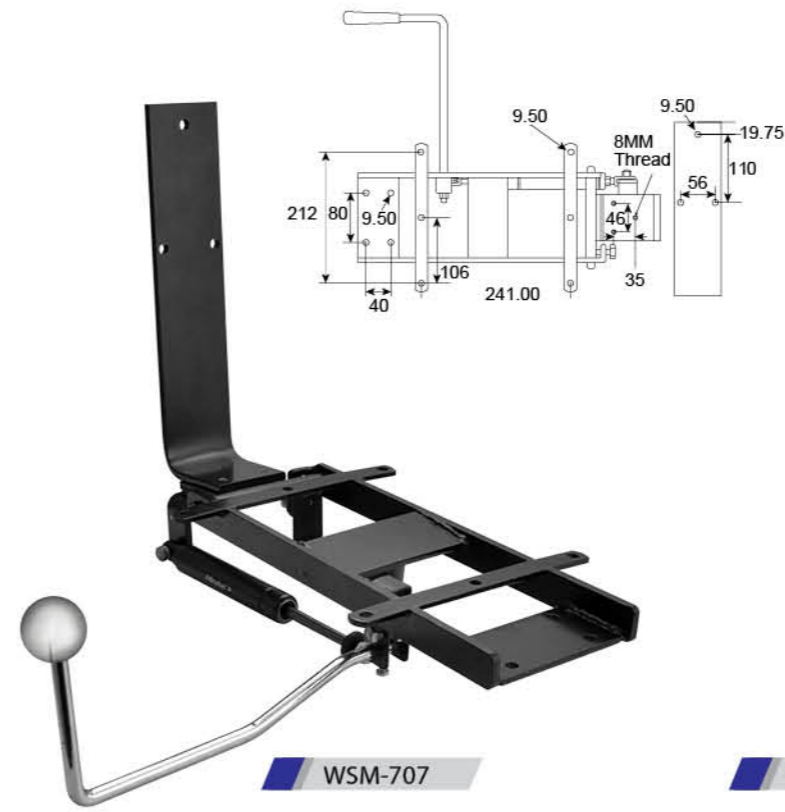

WSM-707



WSM-708



WSM-709

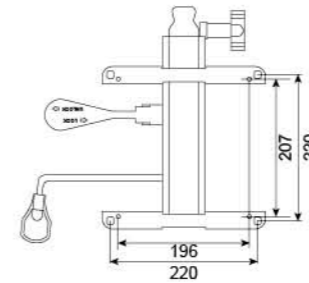

WSM-710

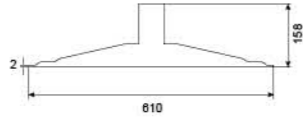

WSM-713

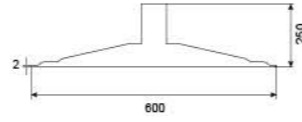

WSM-714

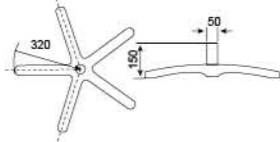

WSM-711



WSM-717



WSM-715

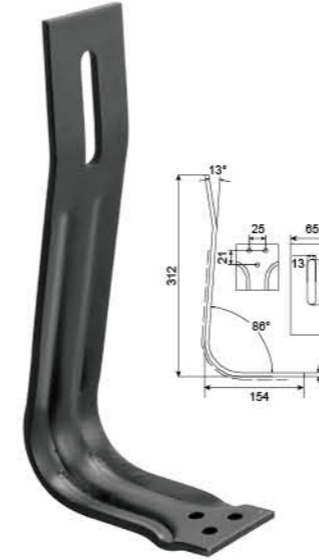

WBP-801

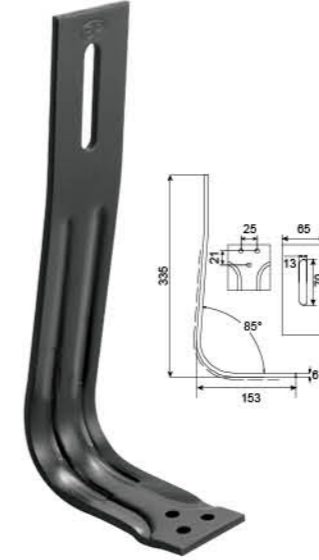

WBP-803

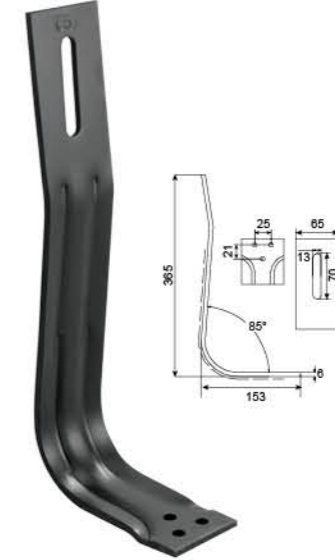

WBP-805



WBP-810

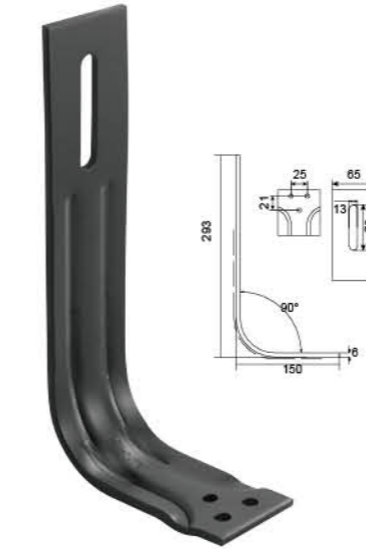

WBP-811

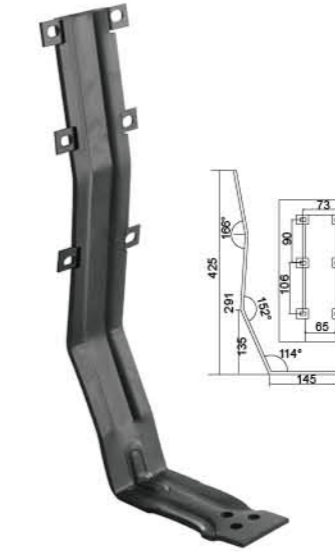

WBP-812

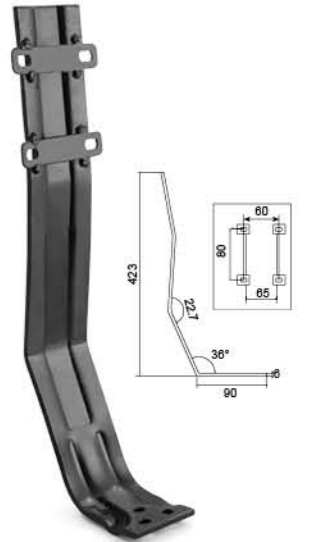

WBP-813



WBP-814



WBP-815

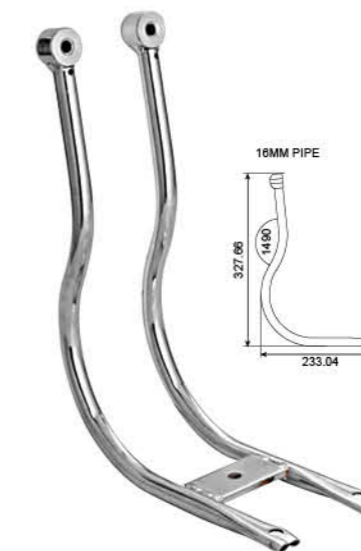

WBP-816

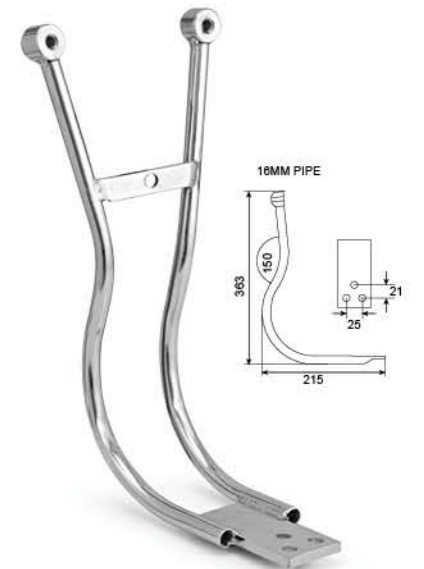

WBP-834



WBP-818



WBP-819



WBP-820

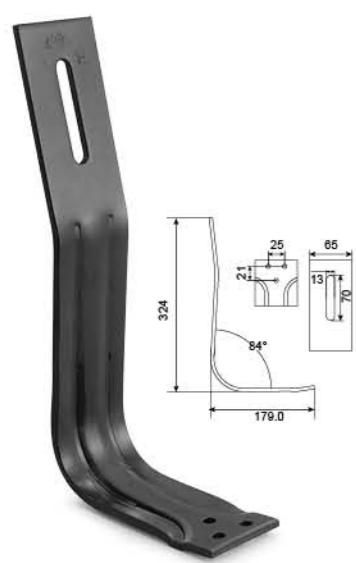

WBP-821



WBP-822



WBP-823

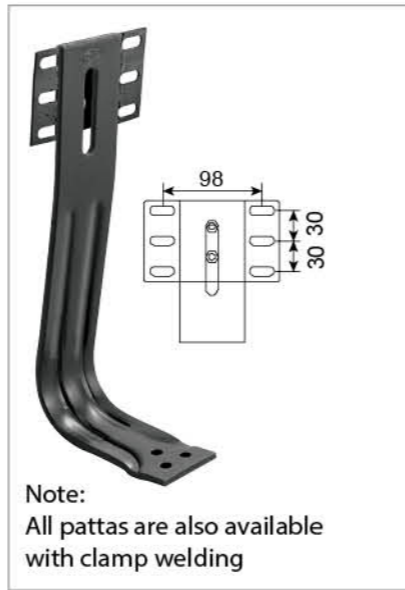

Note:
All pattas are also available
with clamp welding

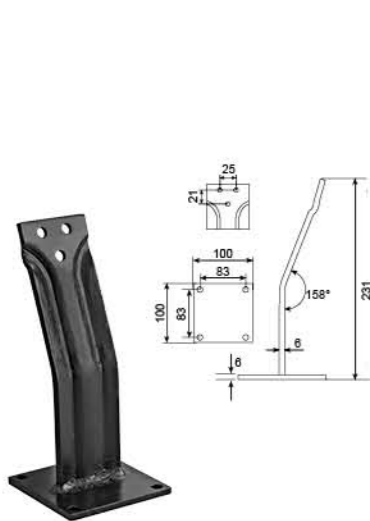

WBP-827

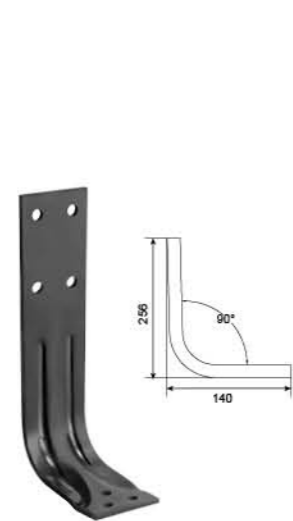

WBP-828



WBP-830

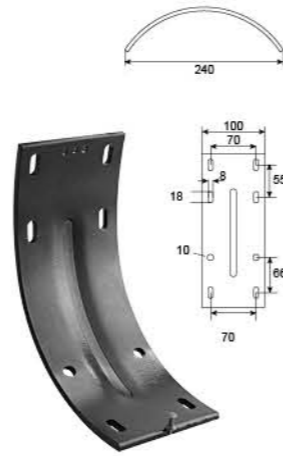

WBP-833



WAR-901



WAR-904



WAR-907



WAR-902



WAR-905



WAR-908

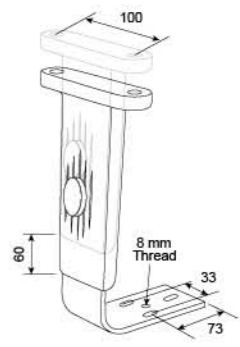



WAR-914



WAR-915



WAR-916



WAR-917



WAR-918



WAR-919



WAR-913



WAR-921

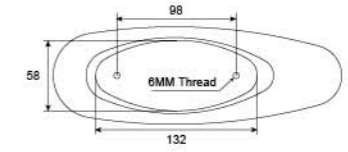

WAR-923



WAR-927

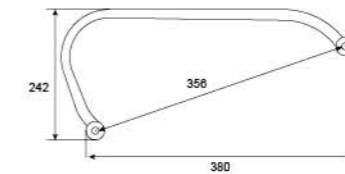

WAR-928

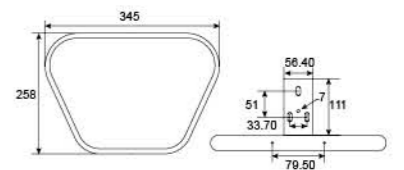

WAR-930

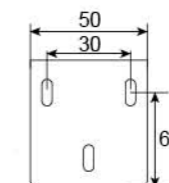



WAR-929



WAR-931

Aluminium Arm

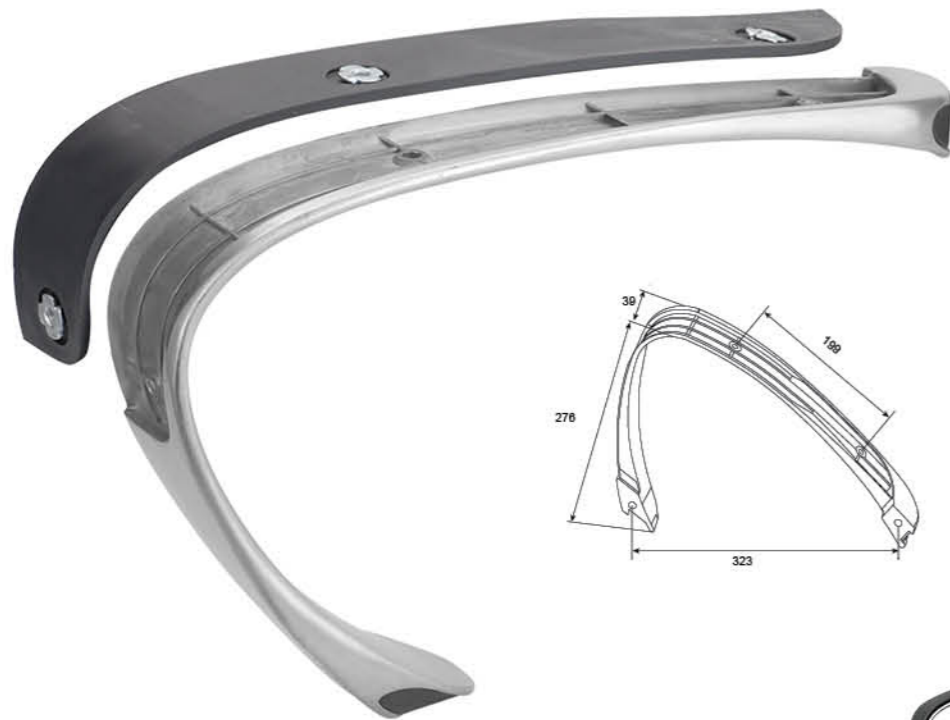

WAR-920



WSC-1001



WSC-1003



WSC-1002



WSC-1004



WSC-1004 A

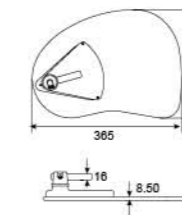

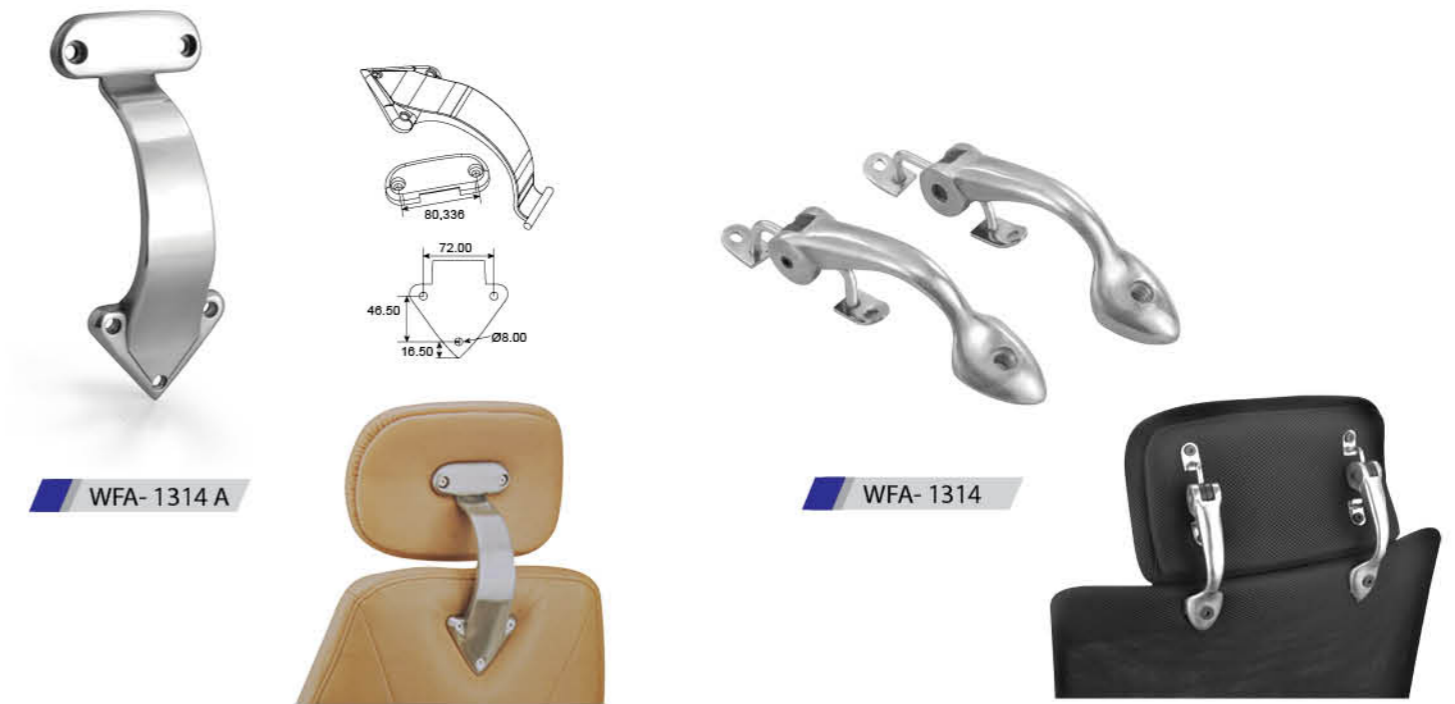
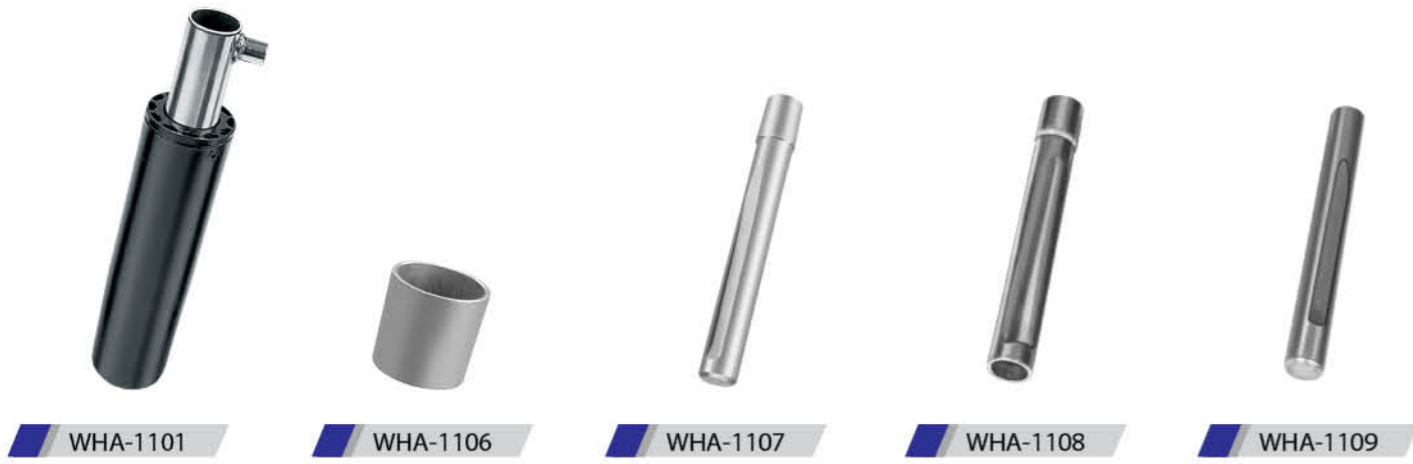

Base Leg



Product Code	Height
WFA-1367	240mm
WFA-1367 A	253mm



WFA- 1316 WFA- 1317 WFA- 1318 WFA- 1319 WFA- 1320 WFA- 1322



WFA- 1325 WFA- 1332 WFA- 1333 WFA- 1340



Product Code	Height	Finish
WFA -1336	660 mm	Chrome
WFA -1336 A	660 mm	Powder Coated
WFA -1366	990 mm	Chrome
WFA -1366 A	990 mm	Powder Coated



Product Code	Height	Size	Finish
WFA -1337	724 mm	Ø 75 mm	Stainless Steel
WFA -1337 A	724 mm	60 mm Sq.	Stainless Steel

In-House Manufacturing

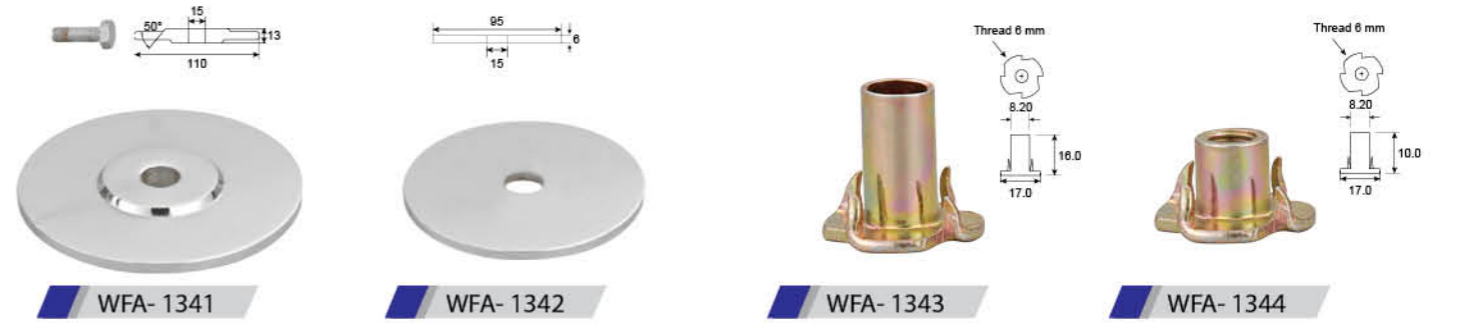

WFA- 1341 WFA- 1342 WFA- 1343 WFA- 1344

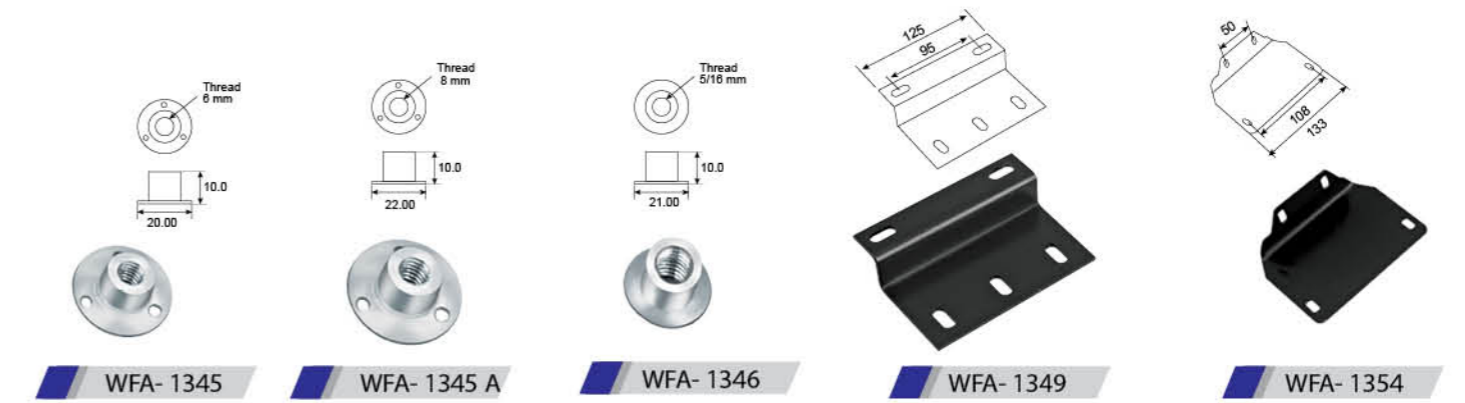

WFA- 1345 WFA- 1345 A WFA- 1346 WFA- 1349 WFA- 1354

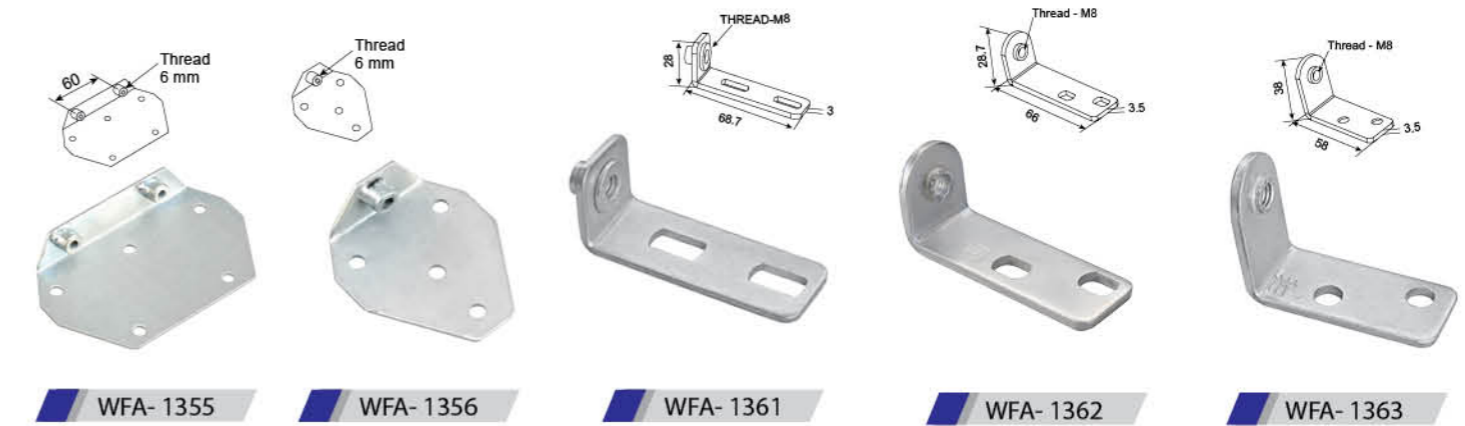

WFA- 1355 WFA- 1356 WFA- 1361 WFA- 1362 WFA- 1363



WFA- 1338 A WFA- 1364 A

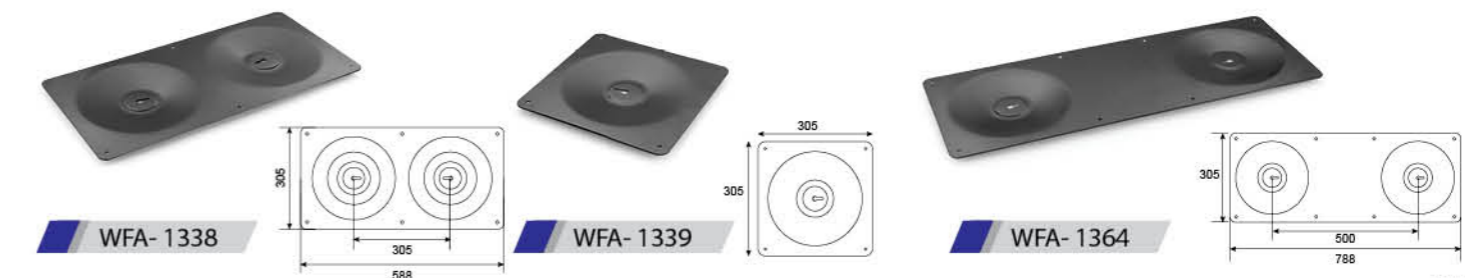

WFA- 1338 WFA- 1339 WFA- 1364

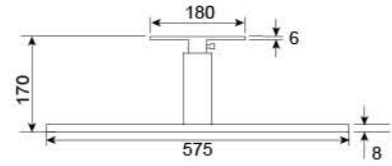

Product Code	Round Base	Finish
WSB-1504	381 mm	Stainless Steel
WSB-1505	482 mm	Stainless Steel
WSB-1506	584 mm	Stainless Steel

WSB-1504 (SS)



WSB-1507

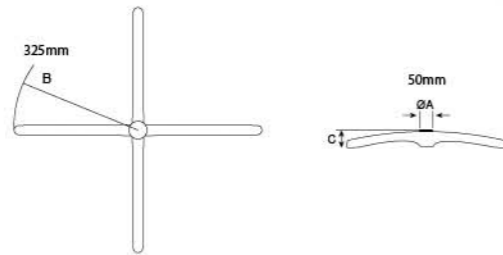

WSB-1508



WSB-1509

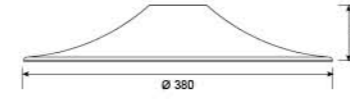

Product Code	Round Base	Thickness
WSA-1601	381 mm	1.2 mm
WSA-1601 A	381 mm	1.0 mm
WSA-1602	457 mm	1.2 mm
WSA-1603	533 mm	1.2 mm

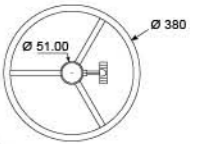

Product Code	Round Base
WSA-1604	381 mm
WSA-1605	457 mm

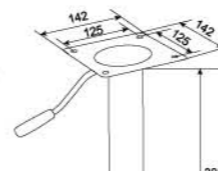

WSA-1606

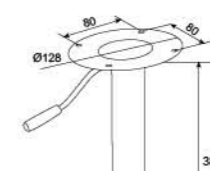

WSA-1606 A

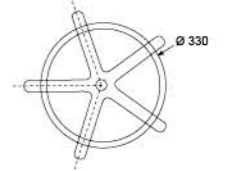

WSA-1609

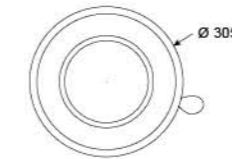

WSA-1608

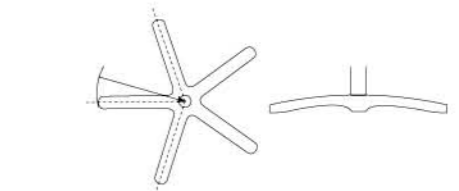

Product Code	A(mm)	B(mm)	C(mm)
WSA-1610	50	245	95



WBS-1701



WBS-1702



WBS-1703



WBP-828



WBS-1704



WBS-1705



WCA-1801



WCA-1802



WCA-1803



WCA-1804



WCA-1805



WCA-1806



WCA-1807



WCA-1808

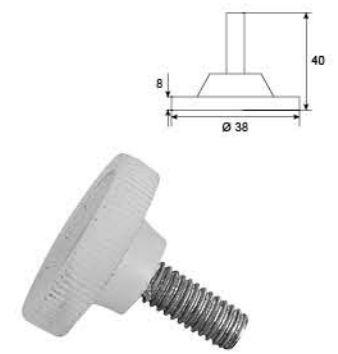

WCA-1809



WCK-1901

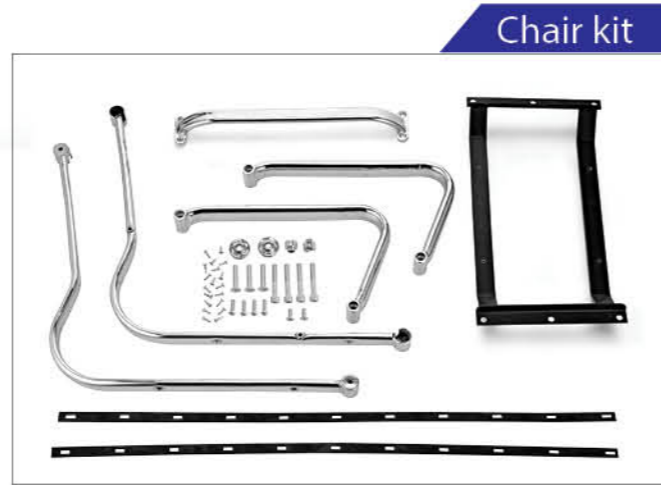
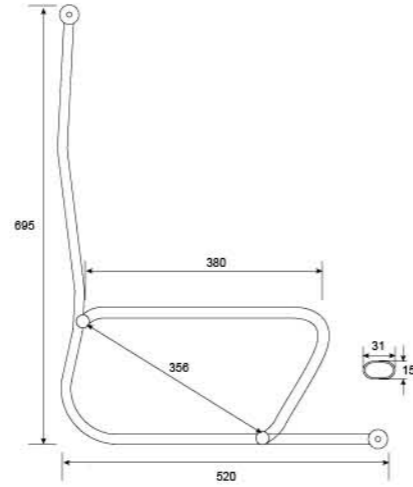

Chair kit



WCK-1902

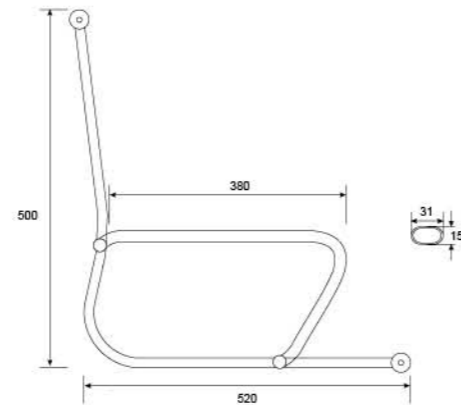

**MORE
THAN JUST
'COMPONENTS'**

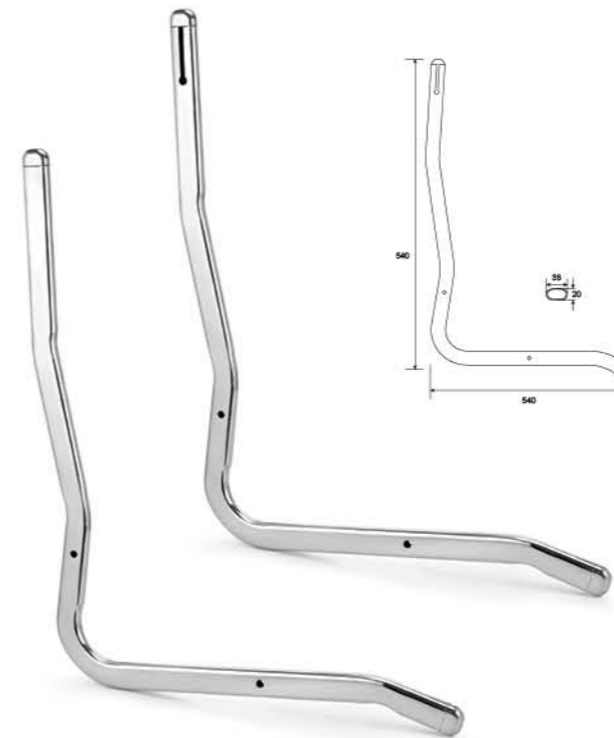

WCK-1903

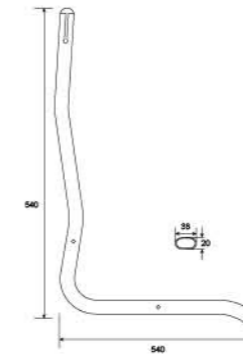

WCK-1904

Powder Coating color options...!

To light up the imagination of designers we offer a range of choices for powder coated surface colors.
Minimum quantity 100 units.

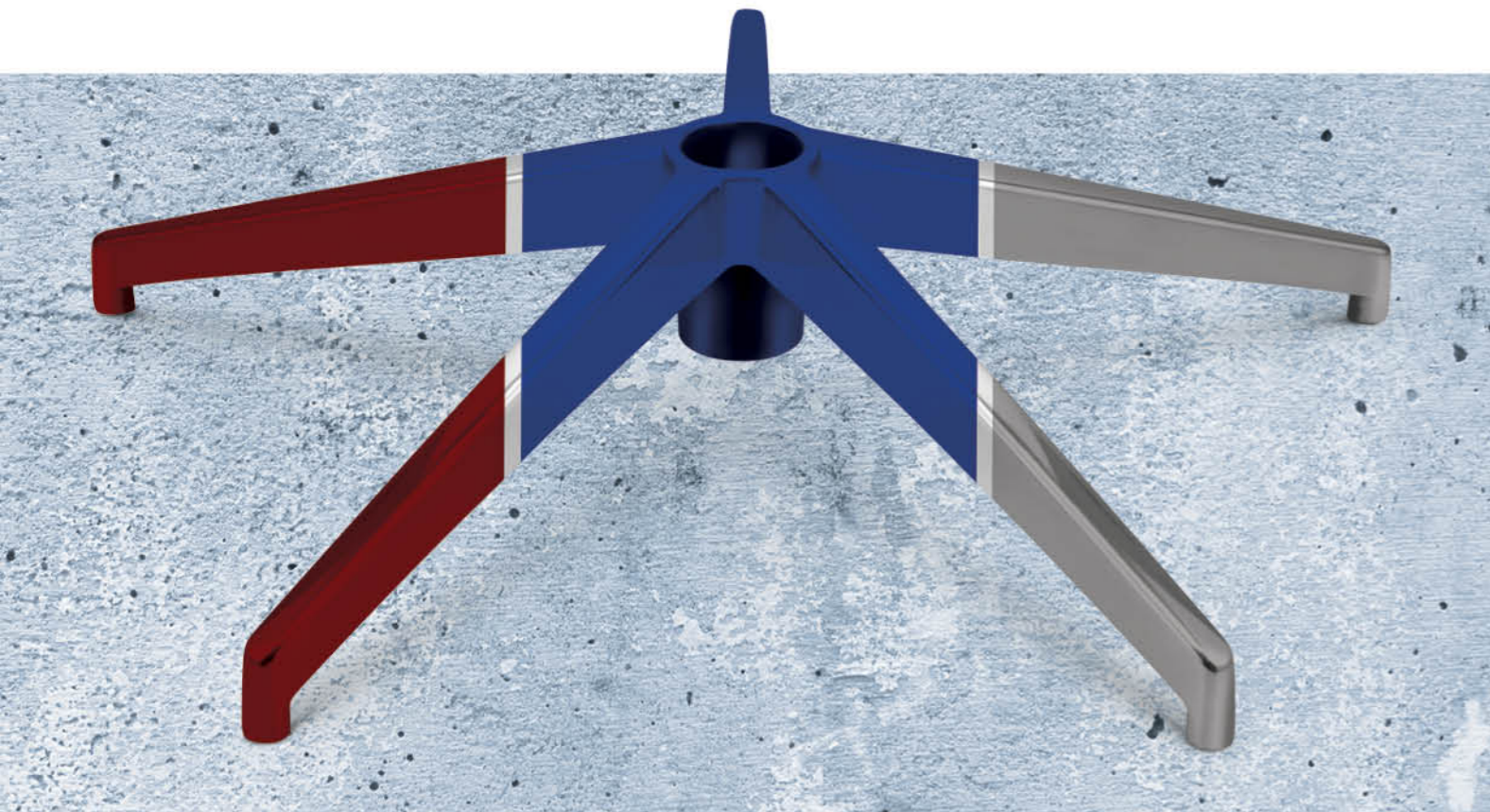

Surface
Powder Coated

Surface
Brushed

Surface
Polished

Surface
Chromium



Mechanism Testing Machine



Castor Testing Machine



Load Testing Machine



Impact Testing Machine

In order to maintain high standards of quality, all World Wide products and components undergo through various stages of rigorous testing procedures before they are finally shipped to the end user



WORLD WIDE PRODUCTS

True Bond of Precision and Excellence

100% Production Under One Roof

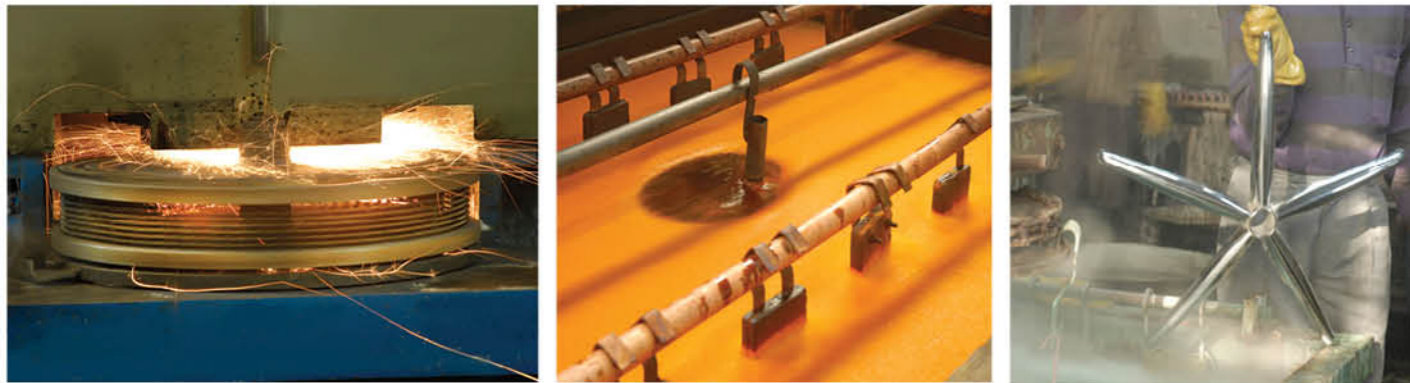



WORLD WIDE PRODUCTS

Head Office/ Showroom:

7/1, 2nd Floor, Furniture Block, W. H. S. Kirti Nagar, New Delhi- 110015. INDIA

Ph: 91-11-25988215, 25989300 Cell: 91-93505 49805

Fax: 91-11-25984878 | Email: info@worldwideproductsindia.com

For Special Enquiry : 91-93505 49809

Branch Office:

9522/13, Multani Dhanda, Pahar Ganj, New Delhi- 110055. INDIA

Cell: 91-93505 49804

Visit us at: www.worldwideproductsindia.com